

SWEAT BEE® YOKE MOUNT

ATTENTION

The safety cable is a crucial part of the fan and must be installed correctly. If you have questions or require assistance, call Customer Service at 1-877-BIG-FANS.

The following instructions are for mounting the fan to an I-beam or bar joists. Consult the complete Sweat Bee Install Guide for all other aspects of fan installation. Consult a structural engineer for mounting methods not covered in these instructions.

Parts and hardware

If you are missing any parts or hardware, contact Customer Service at 1-877-BIG-FANS. *Note: Illustrations below are not to scale.*

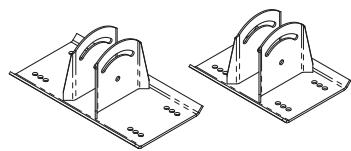

Upper Yoke (Small or Large)

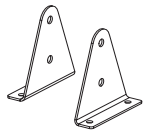

Lower Yoke



(4) Alignment Aids



Adapter Plate



(8) Square Washer

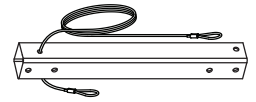

Extension Tube

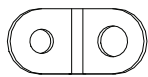

(4) Guy Wire Clip

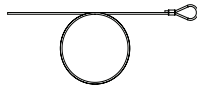

(4) Guy Wire

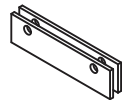

(2) Spacer*

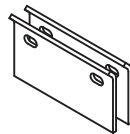

(2) Beam Clip*



(4) Gripple®



(8) Wire Rope Clip

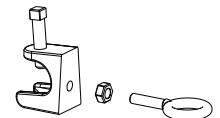

(4) 1/4" Beam Clamp
(4) 1/4-20 Hex Nut
(4) 1/4-20 x 1" Eyebolt

* Used on I-beam application only

Hardware



Extension Tube Hardware

- (4) 1/2-13 x 4-1/2" Bolt
- (2) 1/2-13 x 5" Bolt*
- (4) 1/2" Flat Washer
- (4) 1/2-13 Nylock Nut

Upper Yoke Hardware

- (4) 1/2-13 x 2" Bolt
- (8) 1/2" Flat Washer
- (4) 1/2-13 Nylock Nut

Lower Yoke Hardware

- (4) 3/8-16 x 1-1/4" GR 8 Bolt
- (8) 3/8" Flat Washer
- (4) 3/8-16 Nylock Nut

* 5" bolts are packaged with the guy wire clips.

Preparing the work site

Handling of the fan should be performed by trained personnel and be consistent with all safe handling practices. When surveying the work site, keep the following guidelines in mind. See the Sweat Bee installation guide for additional mounting guidelines.

- Verify that all lifting equipment is in good operating condition and has the proper lifting capacity. The fan should be lifted using well-padded chains, cables, or lifting straps with spreader bars. Never lift the fan by the inlet or outlet guards or any other part of the fan that could distort the fan assembly.
- The fan installation area must be clear of obstructions such as lights, cables, sprinklers, or other building structure parts.
- Consult a structural engineer if you are uncertain of your required mounting method.

MOUNTING STRUCTURE: I-BEAM

⚠ WARNING: The fan should not be installed unless the structure on which the fan is to be mounted is of sound construction, undamaged, and capable of supporting the loads of the fan and its method of attachment. Verifying the stability of the mounting structure is the sole responsibility of the customer and/or end user, and Big Ass Fans hereby expressly disclaims any liability arising therefrom, or arising from the use of any materials or hardware other than those supplied by Big Ass Fans or otherwise specified in these installation instructions.

⚠ CAUTION: Do not fasten the I-Beam mount to vertical I-beams, i.e., I-beams serving as columns.

⚠ CAUTION: Never make swivel and/or rotational adjustments while the fan is connected to power!

⚠ WARNING: The fan should never be operated with loose mounting or adjustment hardware!

1. Attach upper yoke (to I-beam)

Measure the flange width of the I-beam. Consult the tables and diagram below. Select the upper yoke mounting holes that match the flange width of the I-beam.

Secure the upper yoke to the I-beam with the Yoke Hardware as shown. Tighten the bolts to **40 ft·lb (54.2 N·m)**.

Upper Yoke Hardware:

- (4) 1/2-13 x 2" Bolt
- (8) 1/2" Flat Washer
- (4) 1/2-13 Nylock Nut
- (2) Beam Clamp

Small Upper Yoke 13-3/4" (349 mm) x 10" (258 mm)	
I-beam flange width	Upper yoke mounting holes
5" (127 mm) to 6-5/8" (168 mm)	Inner holes
> 6-5/8" (168 mm) to 8-1/4" (210 mm)	Middle holes
> 8-1/4" (210 mm) to 9-7/8" (250 mm)	Outer holes

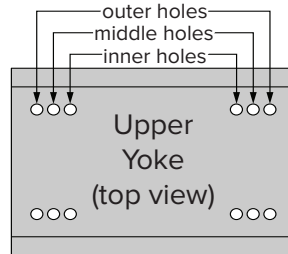

Large Upper Yoke 18-1/2" (470 mm) x 10" (258 mm)	
I-beam flange width	Upper yoke mounting holes
9-7/8" (250 mm) to 11-3/8" (289 mm)	Inner holes
> 11-3/8" (289 mm) to 13" (330 mm)	Middle holes
> 13" (330 mm) to 14-5/8" (371 mm)	Outer holes

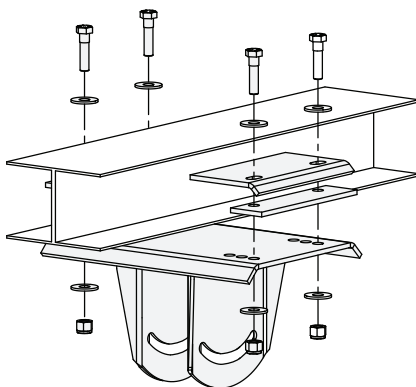

Side View

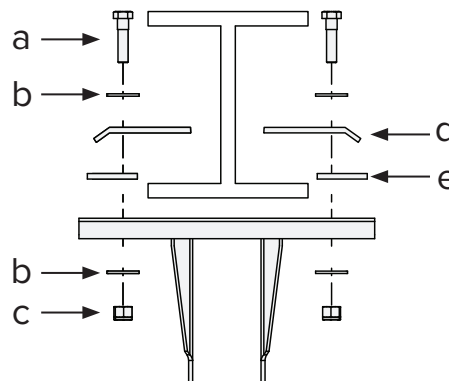

2. Attach extension tube (to upper yoke)

Fasten the extension tube to the upper yoke with the with the Extension Tube Hardware as shown. Before tightening the bolts, allow the extension tube to hang freely and balance itself. Tighten the bolts to **40 ft·lb (54.2 N·m)**.

Extension Tube Hardware:

- a. (2) 1/2-13 x 4-1/2" Bolt
- b. (4) 1/2" Flat Washer
- c. (2) 1/2-13 Nylock Nut

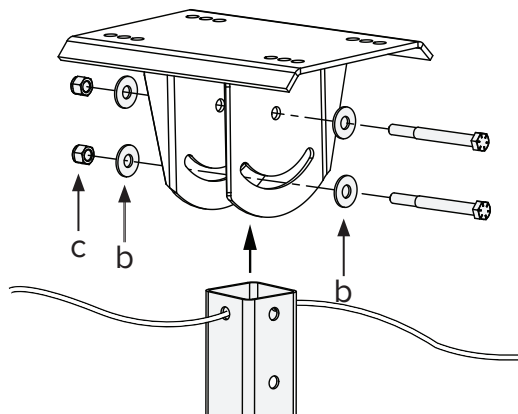

3. Secure safety cable

ATTENTION

The safety cable is attached to the extension tube.

⚠ WARNING: The safety cable is a crucial part of the fan and must be installed correctly. If you have any questions, please contact Big Ass Fans Customer Service.

⚠ CAUTION: Do not connect the safety cable to the fan housing on either end of the fan. Do not connect the safety cable to an area near the blades where it could become tangled in the blades.

Secure the safety cable by wrapping it around the I-beam and connecting the looped ends with the shackle as shown. The cable must be drawn tightly around the I-beam, leaving as little slack as possible. If possible, the shackle should be on the topside of the I-beam. Securely tighten the shackle.

Proceed to Hanging the Fan on page 9.

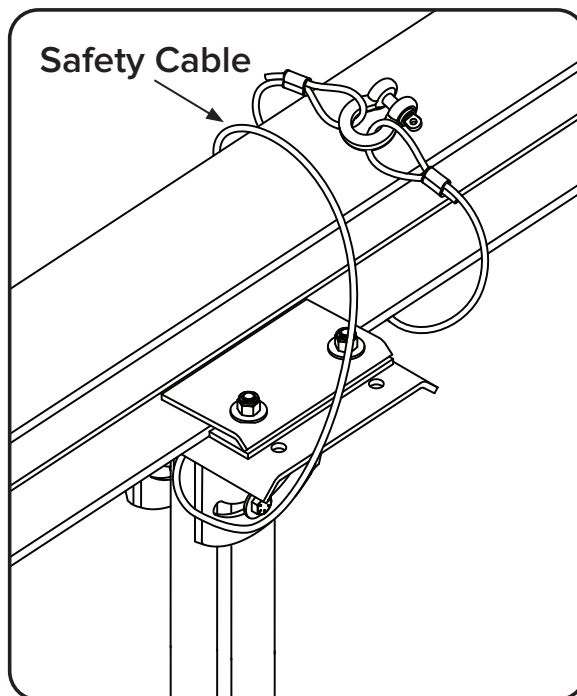
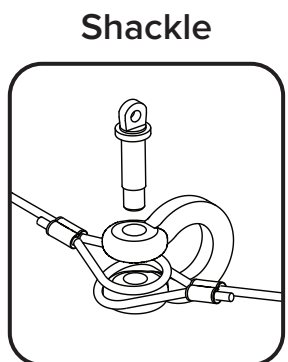

MOUNTING STRUCTURE: ANGLE IRONS

⚠ WARNING: The fan should not be installed unless the structure on which the fan is to be mounted is of sound construction, undamaged, and capable of supporting the loads of the fan and its method of attachment. Verifying the stability of the mounting structure is the sole responsibility of the customer and/or end user, and Big Ass Fans hereby expressly disclaims any liability arising therefrom, or arising from the use of any materials or hardware other than those supplied by Big Ass Fans or otherwise specified in these installation instructions.

⚠ CAUTION: Unsupported angle iron spans should not exceed 12 ft (3.7 m).

⚠ CAUTION: Never make swivel and/or rotational adjustments while the fan is connected to power!

⚠ WARNING: The fan should never be operated with loose mounting or adjustment hardware!

Depending on the angle iron span, the Yoke Mount kit comes with either a small or large upper yoke. Angle irons and angle iron hardware are not included with the Yoke Mount kit. *Note: Never use beam clips when mounting the fan to angle irons! Beam clips are only intended for I-beam installations.*

1. Select proper angle irons

Refer to the table below when selecting angle irons for fan installation. Angle irons and angle iron hardware are not included with the fan.

Angle iron span (between mounting points)	Minimum Angle Iron dimensions (W x H x T)	Number of angle irons needed
6 ft (1.8 m) or less	2.5" x 2.5" x 0.25" (6.4 cm x 6.4 cm x 0.6 cm)	2
6 ft to 8 ft (1.8 m to 2.4 m)	3" x 3" x 0.25" (7.6 cm x 7.6 cm x 0.6 cm)	2
8 ft to 12 ft (2.4 m to 3.7 m)	3" x 3" x 0.25" (7.6 cm x 7.6 cm x 0.6 cm)	4*

*Two pairs of angle irons needed.

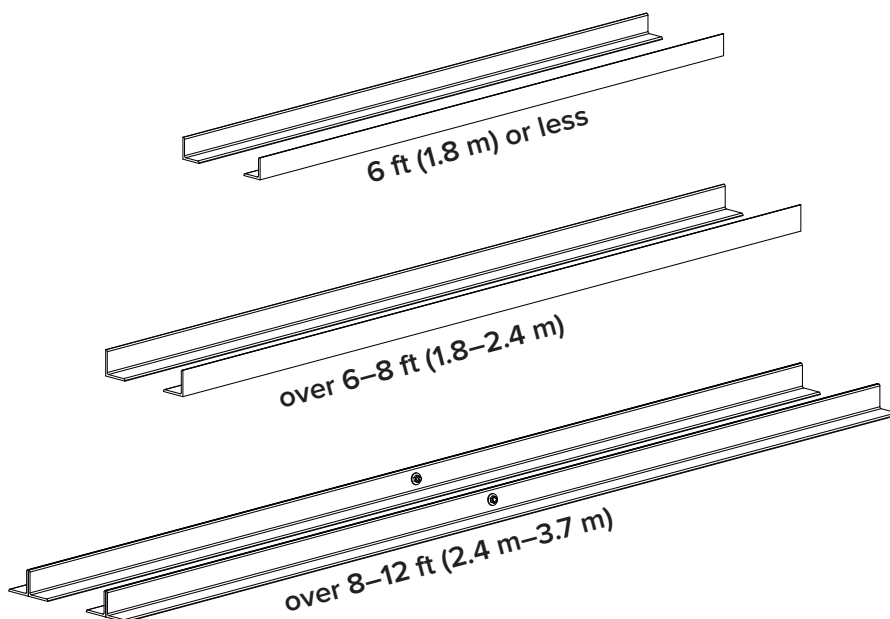

Angle Iron Side View
(see table for dimensions)

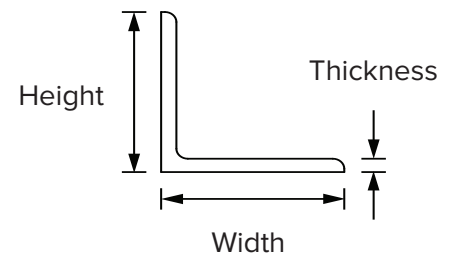

2. Pre-drill angle irons

Drill two $\varnothing 9/16$ " (1.4 cm) holes exactly 5-3/8" (13.7 cm) apart in the centers of two angle irons. If the motor frame will be mounted directly to the angle irons, drill two $\varnothing 9/16$ " (1.4 cm) holes exactly 5-1/2" (14 cm) apart in the centers of two angle irons.

Measure the distance between the mounting points of the roof structure that the angle irons will span. Measure the same distance on the angle irons, and then drill two $\varnothing 9/16$ " (1.4 cm) holes through the ends of the angle irons. If the span is 8 ft (2.4 m) or less, drill holes in the two angle irons. If the span is greater than 8 ft (2.4 m), drill holes in four angle irons.

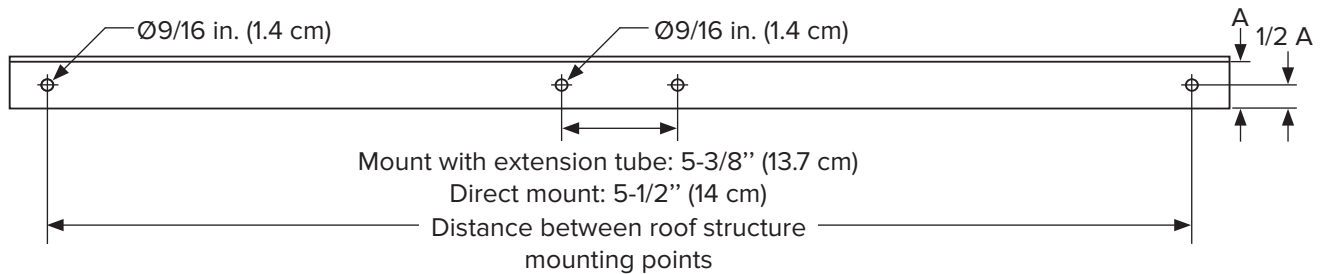

3. Fasten angle irons together

If the angle iron span is 8 ft (2.4 m) or less, skip this step and proceed to step D.

If the angle iron span is longer than 8 ft (2.4 m), use double angle irons. Locate the center of the angle iron length. Drill a $\varnothing 9/16$ " (1.4 cm) hole through the center of the vertical wall of the angle iron. Drill a total of four angle irons.=

Place two drilled angle irons back to back. Fasten the angle irons together with $\varnothing 1/2$ -13 Grade 8 hardware. Align the angle irons to each other and tighten the bolts to **40 ft-lb (54.2 N-m)** using a torque wrench and 3/4" socket.

Repeat this step for the remaining two angle irons.

Proceed to step D.

Grade 8 Hardware (Installer-Supplied):

- a. (2) 1/2-13 Bolt
- b. (4) 1/2" Washer
- c. (2) 1/2-13 Nut

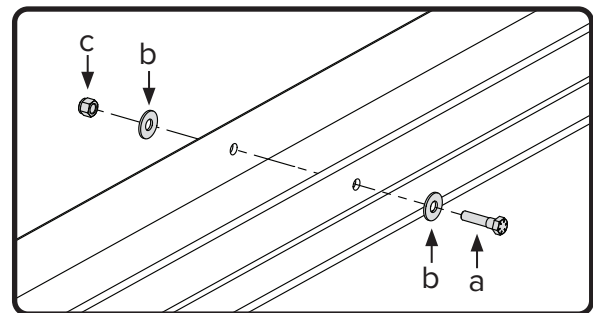

Side view

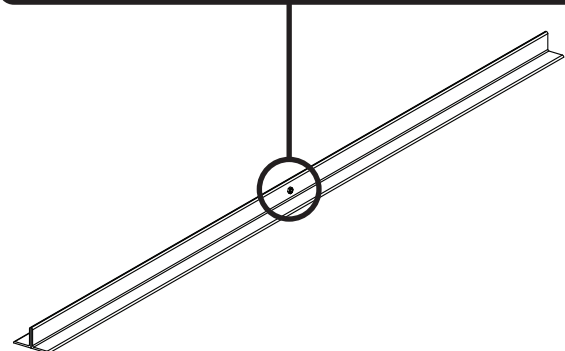
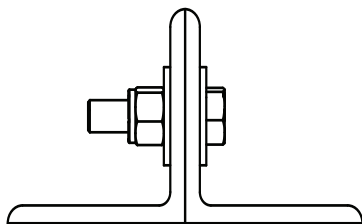

4. Fasten angle irons to roof structure mounting points

Single Angle Iron

Fasten the angle irons to the roof structure mounting points at each end with Grade 8 hardware as shown. Do not tighten the hardware until the upper mount has been mounted to the angle irons (step 5). Big Ass Fans recommend orienting the angle irons so that the horizontal legs are facing each other (or the vertical legs are on the outside). Proceed to step 5.

Grade 8 Hardware (Installer-Supplied):

- (4) 1/2-13 Bolt
- (8) 1/2" Washer
- (4) 3" Square Washer (supplied; see diagram)
- (4) 1/2-13 Nut

Double Angle Iron

Fasten the angle irons to the roof structure mounting points at each end with Grade 8 hardware as shown. The angle irons with fan mounting holes should be positioned on the inside, facing each other. Do not tighten the hardware until the upper mount has been mounted to the angle irons.

Grade 8 Hardware (Installer-Supplied):

- (8) 1/2-13 Bolt
- (16) 1/2" Washer
- (8) 3" Square Washer (supplied; see diagram)
- (8) 1/2-13 Nut

Square Washer

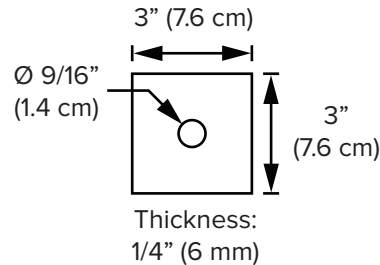

Single Angle Irons

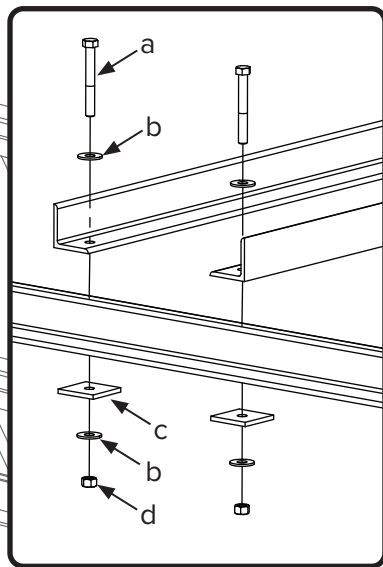

Double Angle Irons

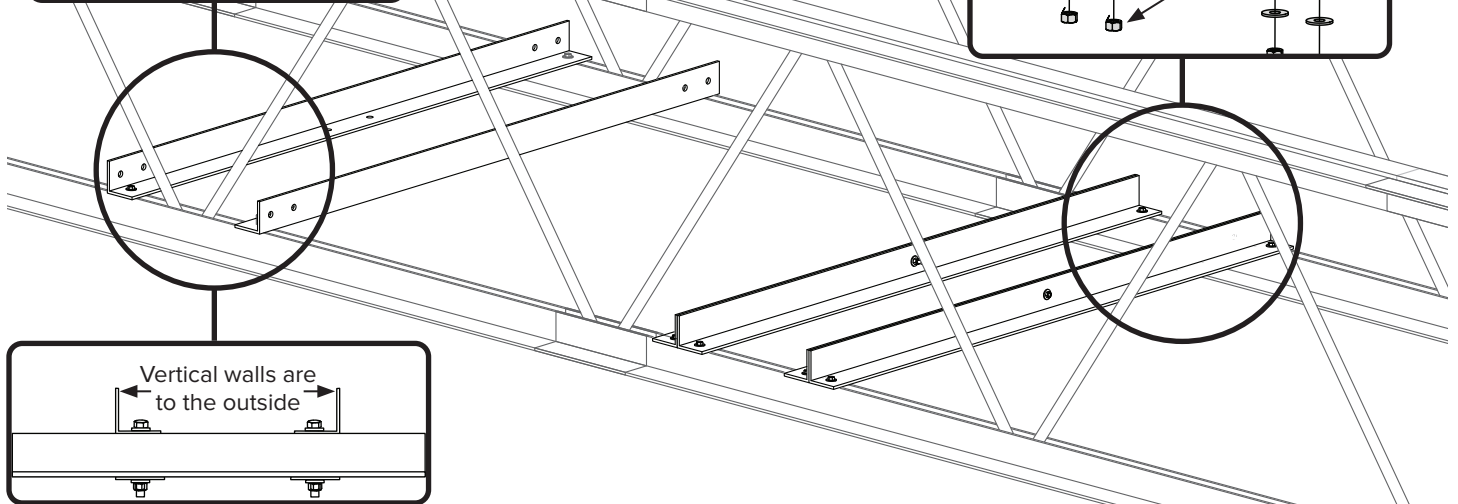
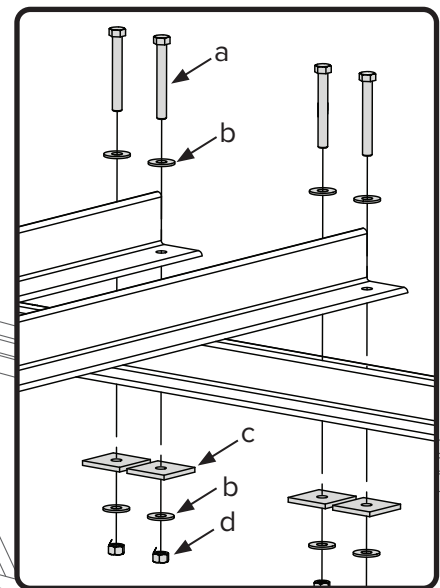

5. Attach upper yoke (to angle irons)

ATTENTION

The angle irons should be aligned with the outermost holes in the upper toke.

Secure the upper yoke directly to the angle irons with the Upper Yoke Hardware. Consult the diagrams below for distances between the angle irons. Tighten the bolts to **40 ft·lb (54.2 N·m)**.

Upper Yoke Hardware:

- a. (4) 1/2-13 x 2" GR 8 Bolt
- b. (8) 1/2" Flat Washer
- c. (4) 1/2-13 Nylock Nut

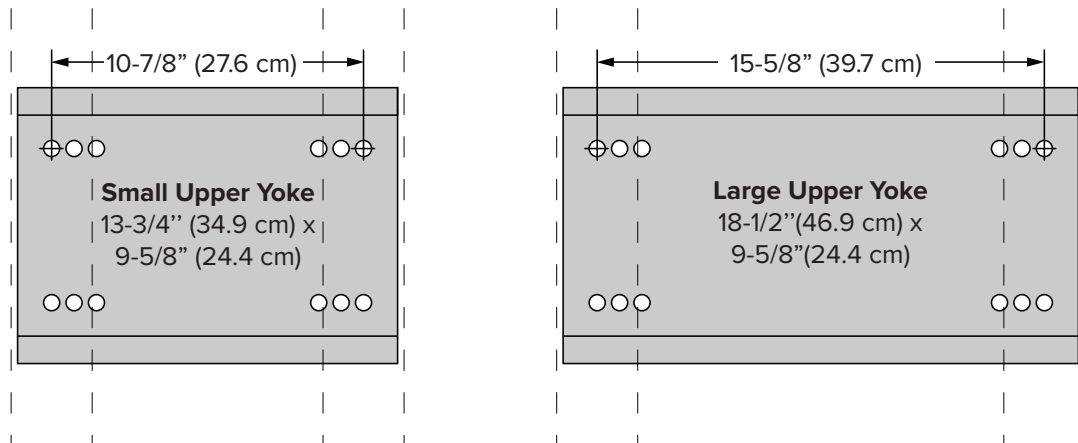

Note: Dashed lines represent angle irons.

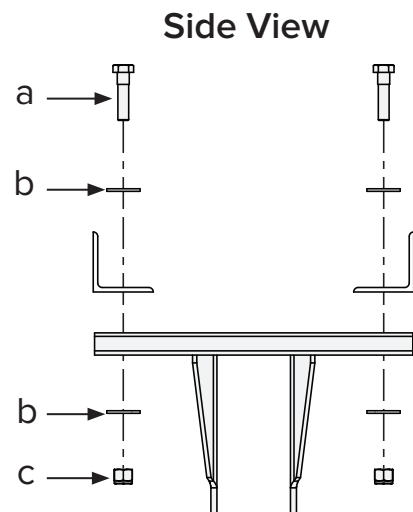
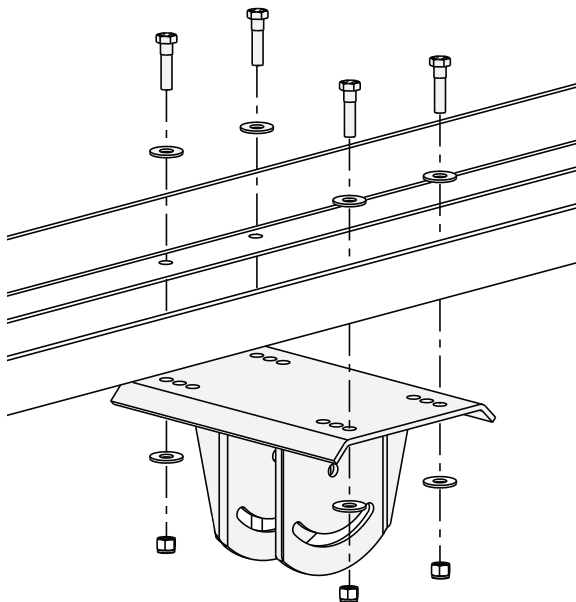

6. Attach extension tube (to upper yoke)

Fasten the extension tube to the upper yoke with the Extension Tube Hardware as shown. Before tightening the bolts, allow the extension tube to hang freely and balance itself. Tighten the bolts to **40 ft·lb (54.2 N·m)**.

Extension Tube Hardware:

- a. (2) 1/2-13 x 4-1/2" Bolt
- b. (4) 1/2" Flat Washer
- c. (2) 1/2-13 Nylock Nut

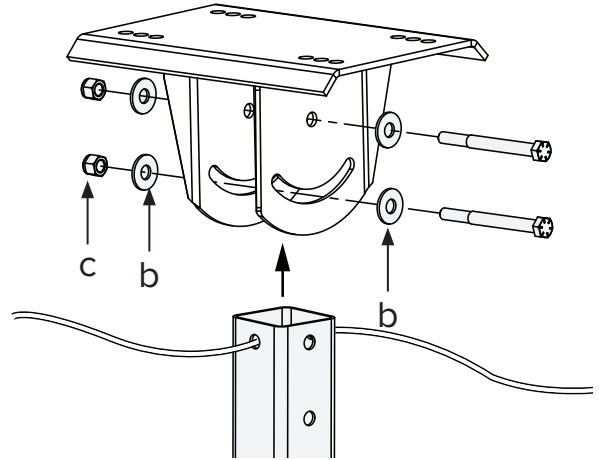

7. Secure safety cable

ATTENTION

The safety cable is already attached to the extension tube.

⚠ WARNING: The safety cable is a crucial part of the fan and must be installed correctly. If you have any questions, please contact Big Ass Fans Customer Service at 1-877-BIG-FANS.

Secure the safety cable by wrapping it around the angle irons and connecting the looped ends with the shackle as shown. The cable must be drawn tightly around the angle irons, leaving as little slack as possible. The shackle should be on the topside of the angle irons if possible. Securely tighten the shackle.

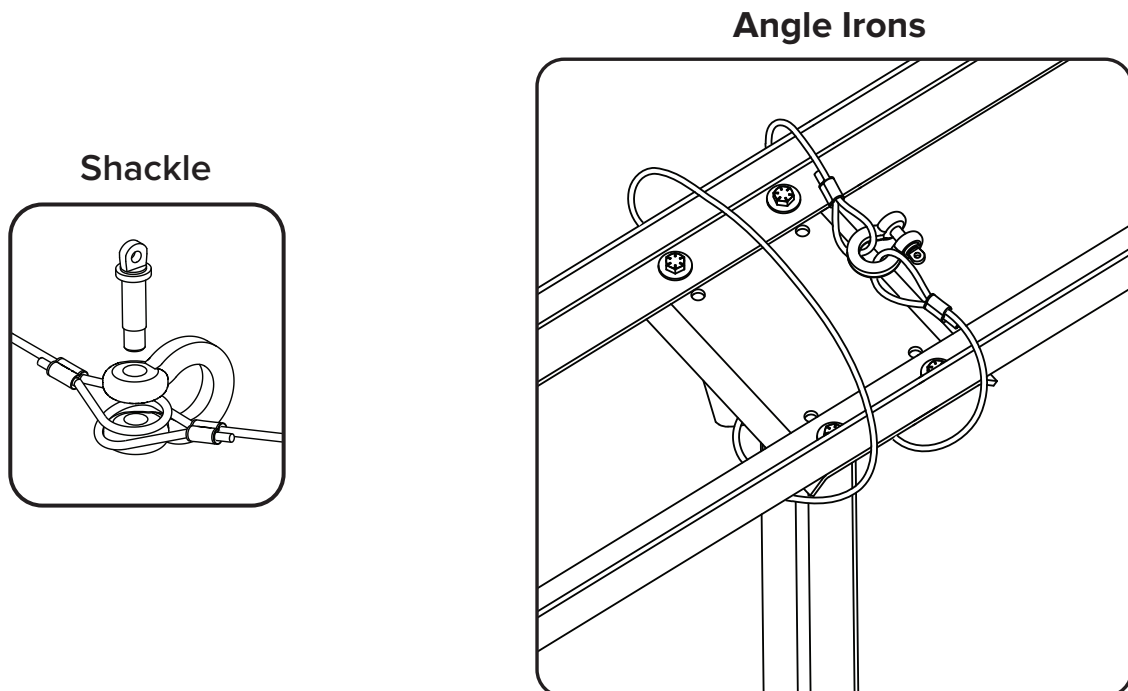

HANGING THE FAN

1a. Attach lower yoke brackets (to extension tube, 3 ft or shorter)

Secure the lower yoke brackets to the lower portion of the extension tube with the remaining Extension Tube Hardware. Tighten the bolts until snug, but do not fully tighten.

Proceed to step 2 on page 10.

Extension Tube Hardware:

- a. (2) 1/2-13 x 4-1/2" GR 8 Bolt
- b. (4) 1/2" Flat Washer
- c. (2) 1/2-13 Nylock Nut

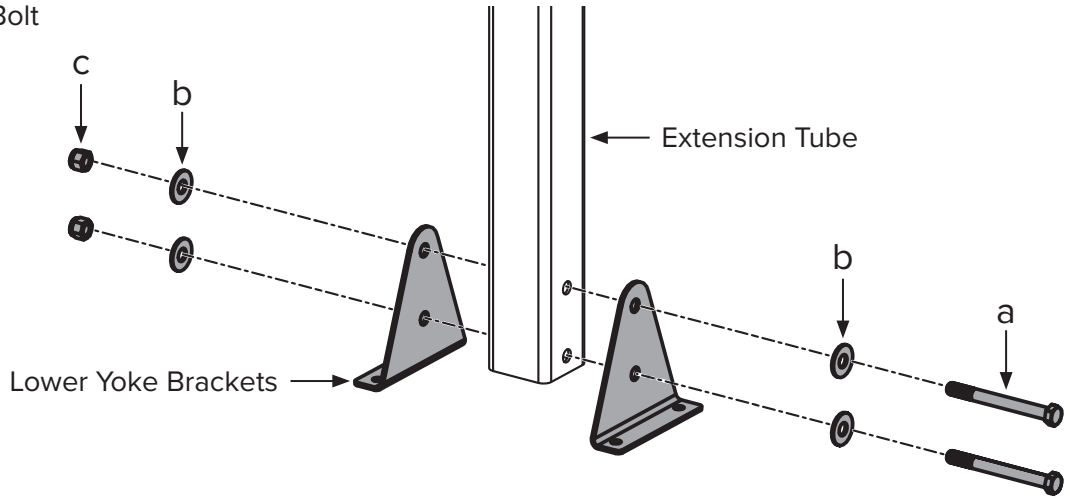

1b. Attach lower yoke (to extension tube, 4 ft or longer)

Secure the lower yoke brackets to the lower portion of the extension tube with the remaining Extension Tube Hardware. Tighten the bolts until snug, but do not fully tighten.

Extension Tube Hardware:

- a. (2) 1/2-13 x 4-1/2" GR 8 Bolt
- b. (4) 1/2" Flat Washer
- c. (4) Guy Wire Clip
- d. (2) 1/2-13 Nylock Nut

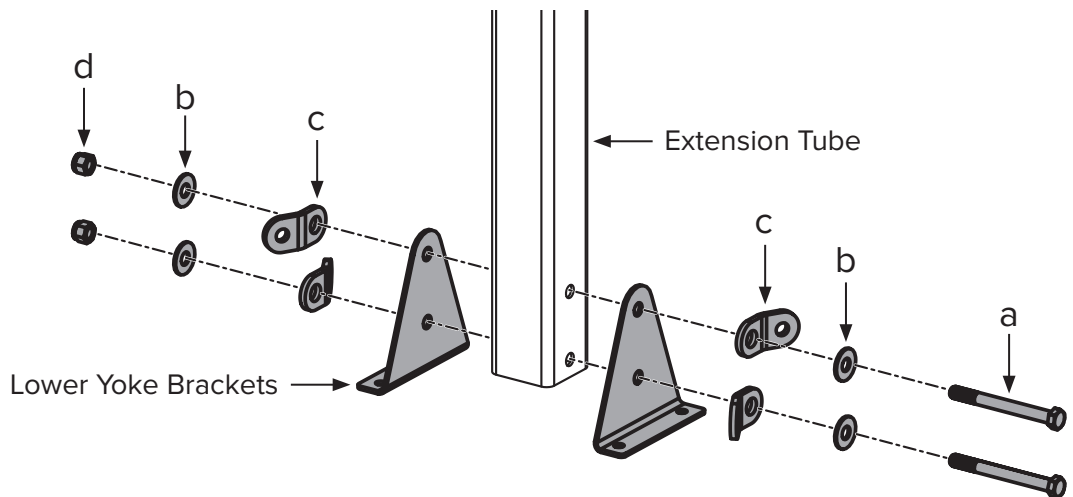

2. Attach beam clamp

Attach the beam clamps to the angle irons. The guy wire should be at a 30°–45° angle from the roof to the extension tube. Place the beam clamp accordingly. Fully tighten the set screw to secure the clamp.

Fasten the small eyebolt and nut onto the beam clamp. The nut will be on the outside of the beam clamp.

Loop the guy wire through its crimped end to secure it to the eyebolt as shown.

Guy Wire Hardware:

- a. (4) 1/4" Beam Clamp
- b. (4) 1/4-20 x 1" Eyebolt
- c. (4) 1/4-20 Hex Nut
- d. (4) Guy Wire

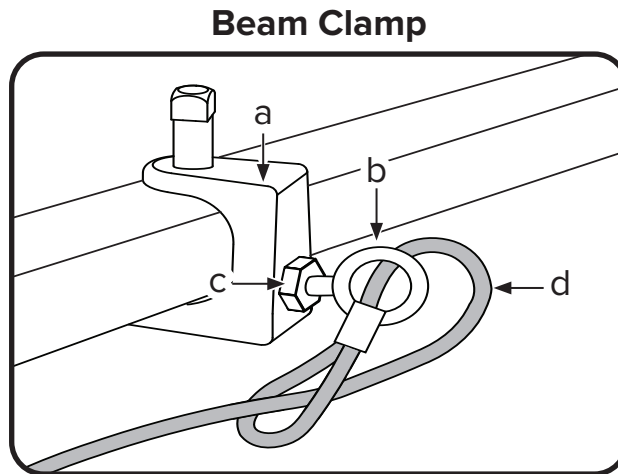

3. Route guy wire through Gripper[®]

Route the guy wire through the Gripper, the guy wire clip at the bottom of the extension tube, and back through the Gripper as shown. Do not tighten the Gripper until the remaining guy wires have been installed.

Note: To back the guy wire out of the Gripper, insert a 1/16 (1.5 mm) Allen wrench into the small hole on the Gripper.

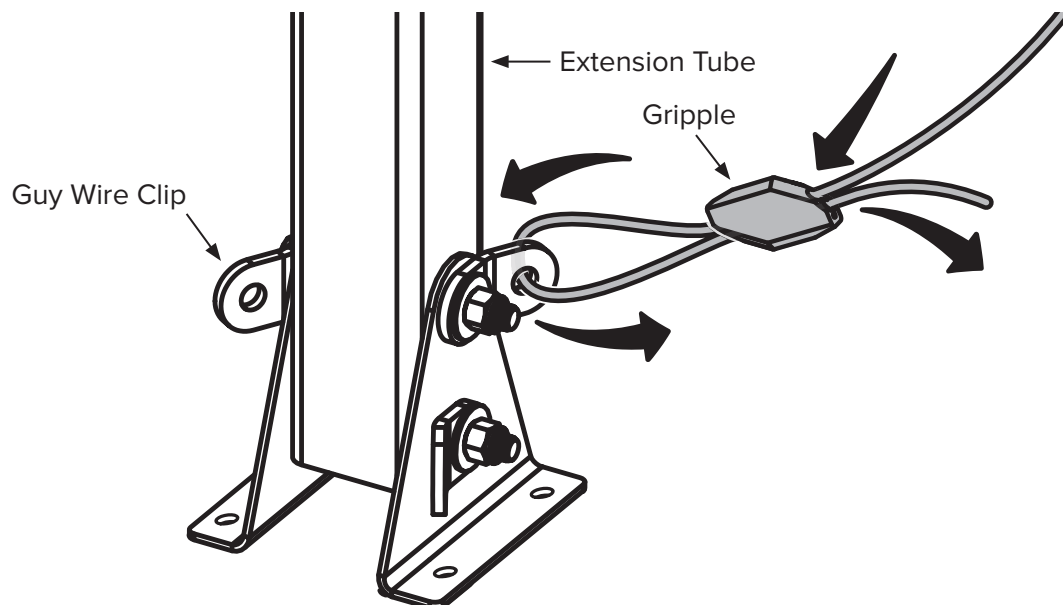

4. Install remaining guy wires

⚠ CAUTION: Over-tightening the guy wires could throw the fan off balance.

Repeat steps 2–3 to install the three remaining guy wires.

Evenly cinch all four guy wires into place using the Gripples®. The guy wires should be taut and evenly spaced around the extension tube.

Once all of the guy wires are taut, secure their loose ends with the wire rope clips and torque to **4.5 ft·lb (6.1 N·m)**. *Ensure all electrical cords/cables are unobstructed by the guy wire system.*

Wire Rope Clip

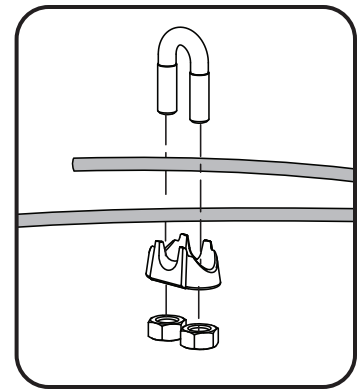

5. Attach fan (to lower yoke)

⚠ CAUTION: Ensure the position locking pin is secured prior to attaching the fan to the lower yoke attachment bracket!

Secure the fan yoke to the lower yoke with the alignment aids, adapter plate and Lower Yoke Hardware as shown below. Fully tighten the bolts to **40 ft·lb (54.2 N·m)**. Allow the fan to hang and balance itself, and then fully tighten the Extension Tube Hardware (securing the lower yoke brackets) to **40 ft·lb (54.2 N·m)**.

Note: Guy wires and Guy Wire Hardware (if used) are not shown in the illustration below. The procedure for attaching the fan to the lower yoke is the same with or without guy wires installed.

Lower Yoke Hardware:

- a. (4) 3/8-16 x 1-1/4" GR 8 Bolt
- b. (8) 3/8" Flat Washer
- c. (4) 3/8-16 Nylock Nut

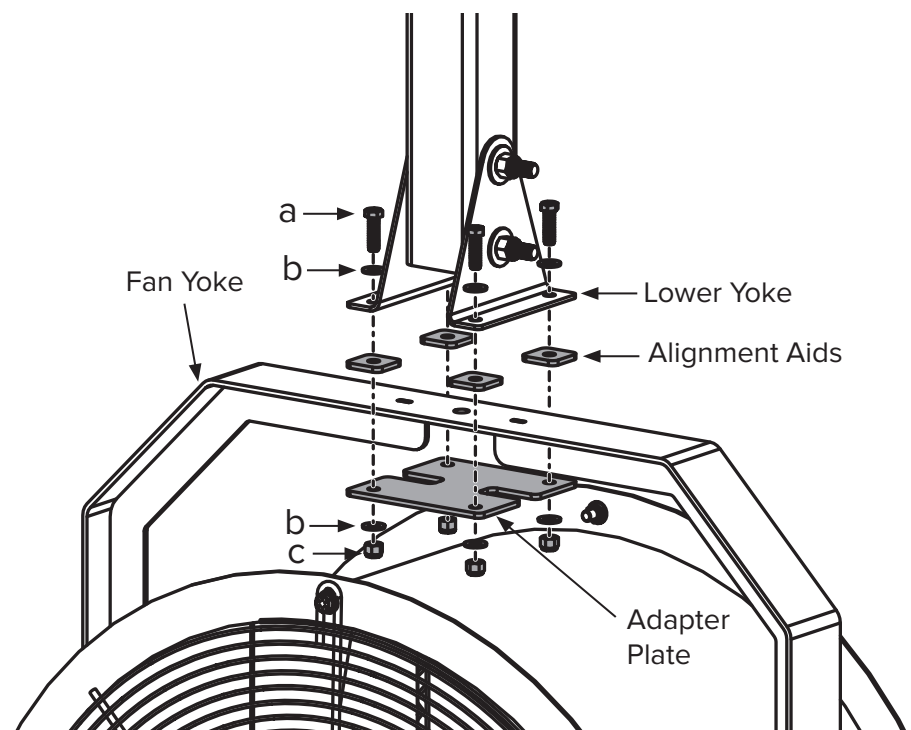



SWB-INST-89-ENG-01
REV D